



Natural wood
Made to last

Installation Guide Character Decking and Boardwalk

2024-01-01



Installation Guide

Kebony

Kebony supplies decking materials that must be used in Use Class 3 (EN 335), for outdoor use above the ground and not in contact with the soil. This guide provides instructions for installing **Kebony Character Decking** and **Kebony Character Boardwalk** in order to produce an attractive and durable result. Local conditions and building regulations must always be taken into consideration. This guide assumes that the installer has the necessary professional competence.

Kebony is a modified wood product in which the timber's properties are permanently changed and enhanced through an eco-friendly process without the use of toxins. Our process yields a stable, hardwearing, long-lasting and beautiful decking material. Kebony wood will behave like natural timber and will swell and shrink along with changes in the environment in which it is installed.

It is recommended to use the principles of constructive wood protection for the entire construction and solutions for untreated timber outdoors. Pay particular attention to the design and execution of end-grain and ventilation and avoid moisture traps. In this guide, we show examples of good solutions that adhere to these principles.

Kebony products must be stored dry until installation and should be covered in plastic until use.

Appearance

Kebony decking has a dark brown colour when supplied. Once the decking has been exposed to rain and sunlight over time, the surface will change and gradually develop a natural silver-grey patina. Since the effects of weather around a building can vary, there will also be variation in how the wood changes colour due to different orientations. Physical global location and local climate will also have an influence on the tempo of weathering. Some surface cracks and fissures are natural in timber that is installed outdoors without surface treatment. Initially, the runoff of rain from a Kebony surface will have a dark colour that may be visible on some light surfaces.

Timber and Metal

Kebony can be combined with stainless and acid-proof steel, enamelled or coated fittings and aluminium without the timber becoming discoloured. When using other combinations, the runoff from Kebony timber may cause discolouration and corrosion. For example, zinc fittings can corrode, while copper ones will remain bright where exposed to runoff from the wood. Runoff from galvanised or ferrous metals to Kebony will result in a dark discolouration of the wood.

Fastenings in contact with the timber must be made from acid-proof (A4) or stainless (A2) steel. A4 is generally recommended and must always be used in coastal areas and chloride environments. Screws of a different quality or use of A2 in the wrong environment may result in dark discolouration around the screw holes.

Extended warranty

Kebony decking is covered by a long warranty against damage by decay through mould. It is a condition of the warranty that the requirements in this installation guide are followed. Where concepts that must be emphasised are specified, this is required for validity of the extended warranty.

Kebony Character Decking

Kebony decking is installed on wooden or aluminium beams, with a minimum of a 3-beam span.

Distance bands, clips or similar must be used to provide a minimum distance of 6 mm between decking above and the beams below. This reduces moisture accumulation and improves ventilation. Kebony distance band on a roll (7x15x10000 mm) is recommended, which also reduces the noise of footsteps and increases comfort.

Decking boards must be installed so that the side with rounded side edges faces upwards.

Use edge fastening to avoid chipping and the accumulation of water around screw holes. For edge fastening, it is recommended to use a screw jig from **Camo™ Fasteners** with **60 mm or 75 mm screws**. Always follow the supplier's guidelines.

If top fastening is used, it is important not to countersink the screws into the decking. The screw must be flush with the surface of the timber. Recommended screw sizes are minimum 5x60 mm for 28 mm thick decking and 5x70 mm for 34 mm thick decking.

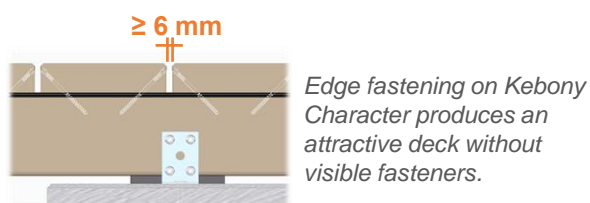

Figure 1: Edge fastening of Kebony Character Decking

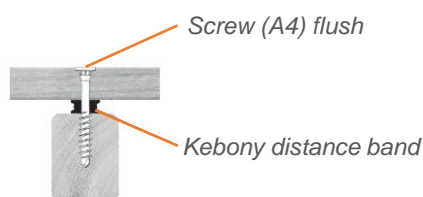

Figure 2: Kebony Distance Band

Other than cutting the boards to length, further machining on **Kebony Character** should be avoided since this will expose untreated heartwood. All cut surfaces must be treated with **Kebony End-grain Sealing Wax**, or equivalent. Follow the manufacturer's instructions.

Minimum spacing gaps

- Between decking boards: 6 mm
- Against building: 15 mm
- Skirting boards and ends: 5 mm

Kebony is dried during production, and some swelling must be anticipated after installation.

This applies to both the length and width and will be especially visible at mitred corners if this is not allowed for.

TIP: For decks with high traffic, such as public facilities, a larger spacing gap between decking boards is recommended to simplify cleaning.

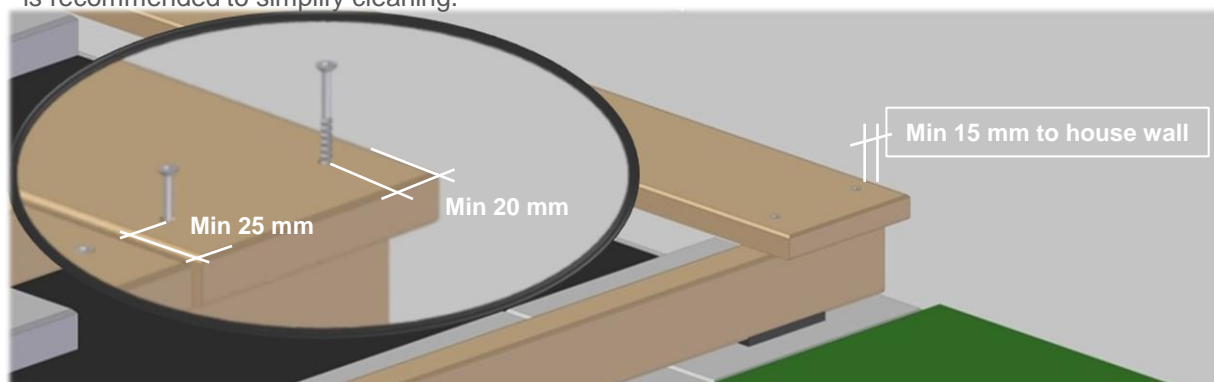

Figure 3: Distance from building & screw positions

Ends and joints

For an attractive result, all ends should be neatly cut and finished with a small chamfer or bevel.

All cut surfaces must be treated with **Kebony End-grain Sealing Wax**, or equivalent. This both protects the wood and reduces the risk of ends splitting.

Sharp edges at the ends of boards are rounded or bevelled, this reduces chipping and providing a more comfortable surface to walk on. TIP: Use an edge router with a rounding radius of 3-5 mm.

Board-ends should always have an overhang over the last beam, do not end it flush with or directly on a beam.

Longitudinal decking joints (where ends of boards meet) must be made over two beams. There should be a gap of at least 5 mm between the board ends to let them dry out and give the wood room to expand.



Figure 4: End-sealing with Kebony End-Grain Sealing Wax is recommended as part of best practice – this reduces the risk of ends splitting.

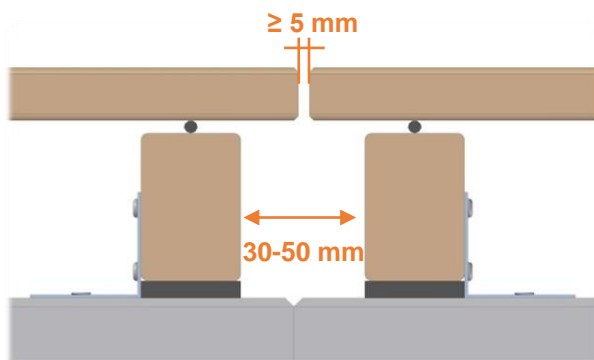

Figure 5: Decking board with EPDM pads over 2 beams. This method increases longevity and simplifies cleaning.

TIP: Kebony Character may have some dimensional variation. The jointing method shown above will produce neat and tidy joints, even with a degree of variation in the wood. If another method is used, it is advisable to check that the joined ends fit together before fastening.

Beams

Maximum recommended beam spacing (c/c), ordinary deck (*)

Kebony Character decking, 28 mm: 60 cm

Kebony Character boardwalk, 34 mm: 90 cm

*With a 2.0 kN concentrated load, decking board installed over minimum 2 spans, maximum deflection is 5 mm. With higher loads, the beam spacing must be reduced.

The beams are attached to the substrate/substructure and stiffened. Where it is not possible to attach the beam to the substrate, a torsionally rigid structure using crossbeams must be made.

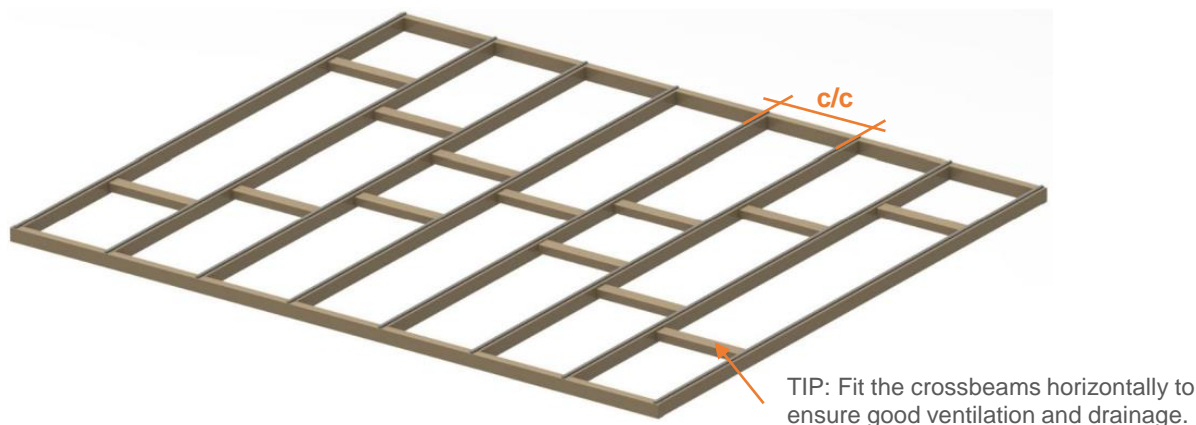

Figure 6: Example of stiffening of joist layer.

Ventilation

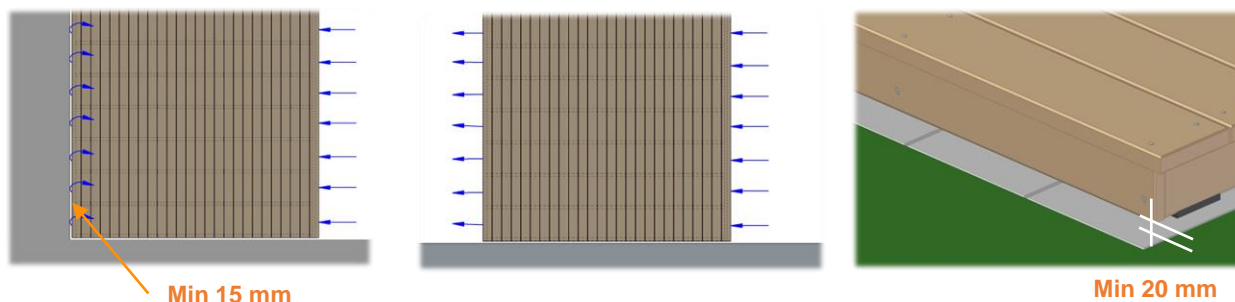

Figure 7: Ventilation design & minimum spacings

The structure below the decking must be sufficiently ventilated so that wood that gets wet can quickly dry out again. This can be achieved by having openings along at least two sides so that the air circulates beneath the decking. If one of the sides is against a wall, there must be an opening of at least 15 mm between the wall and the end of the decking. Any skirting board must finish at least 20 mm above the ground/substrate to allow air to circulate. For large decks, damp environments or poor airflow, additional measures must be taken to ensure adequate ventilation, such as the use of the 0 **Kebony Ventilation Profile**.

Planning

- Structures must comply with local regulations.
- For decking adjacent to buildings, the substrate must slope away from the building or be drained so that surface water is effectively removed.
- The substructure must be made from materials of equivalent or better longevity than the decking in order to ensure that the entire structure is durable.
- To prevent water from pooling on the decking, we recommend a slope along the length of the decking. If the deck is built without a slope, more care and maintenance is to be expected.
- To prevent moisture migration in the structure, a capillary barrier should be used between different types of materials. This protects the structure and increases its longevity.

Kebony decking boards are supplied in fixed lengths. Plan the construction to use entire lengths and make efficient use of the material. Large terraces can, for example, be divided with a crossboard. Remember to allow end-finishing as described under “Ends and Joints” when planning lengths

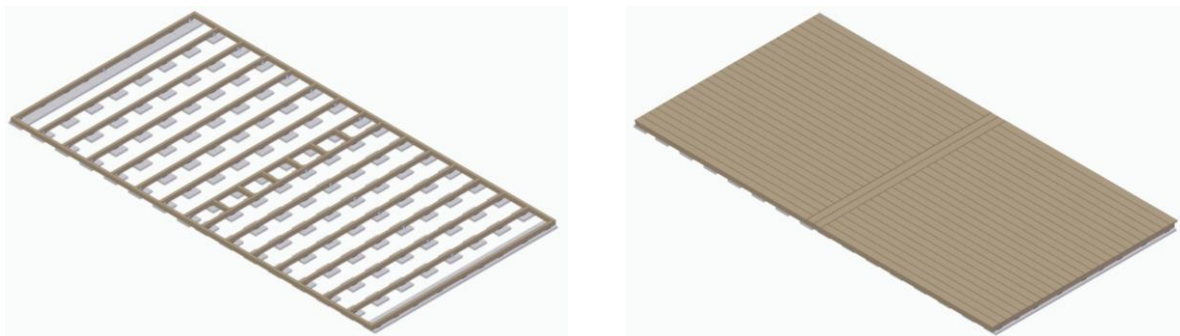

Figure 8: Example of a terrace divided into zones. Such solutions make extremely good use of material and create an exclusive appearance. Adapt the size of the zones to the length of the decking boards.

Decking on fixed substrates (concrete, tiles, etc.)

Decking can be installed on beams on a fixed substrate, such as concrete, tiles, membranes and similar. The substrate must have a sufficient slope of at least 1.5%, to avoid water collecting under the decking.

Decking bearers can be used, but these must always be laid in the direction of the slope. A moisture barrier must be laid between the bearers and the substrate. The distance from the lower edge of the decking to the substrate must be at least 40 mm, and adequate ventilation must be ensured.

Decking directly over the ground

The substrate must be stable and free of wet soil mass, and landscaped so that the surface water is drained or runs away from the decking. On soft substrates and soil, geotextile fabric and a draining layer must be used, such as gravel, levelled with fine gravel, at least 200 mm thick. The distance from the lower edge of the decking to the ground must be at least 100 mm. Any frost heaving measures must be assessed according to local conditions.

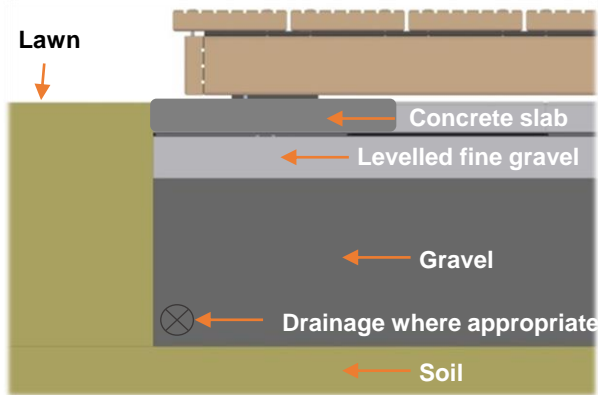

Figure 9: Substrate Design



Figure 10: Spacing to grass

Ensure separation from grassy areas to prevent the decking boards taking up moisture. This separation could consist of kerb stones, or an edge board covered with a foundation membrane. If possible, maintain a distance of at least 50 mm from the decking to the edge of the lawn, so that it is possible to cut the lawn without damaging the woodwork. Remember to have at least two open sides under the decking for ventilation. Beams close to the ground must be laid on concrete slabs or similar.

Decking directly over the ground continued

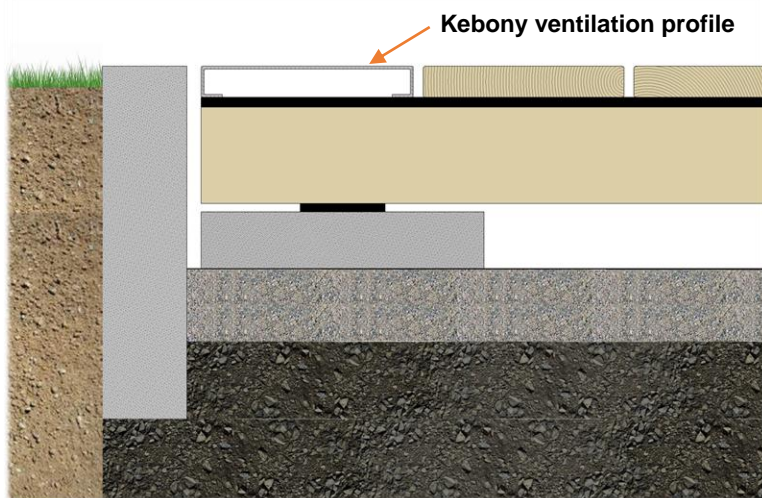

For decking close to the ground or in other places where achieving sufficient airflow is difficult, the **Kebony ventilation Profile** should be used. Remember to have at least two open sides.

Figure 11: Kebony Ventilation Profile & kerb & ventilation design

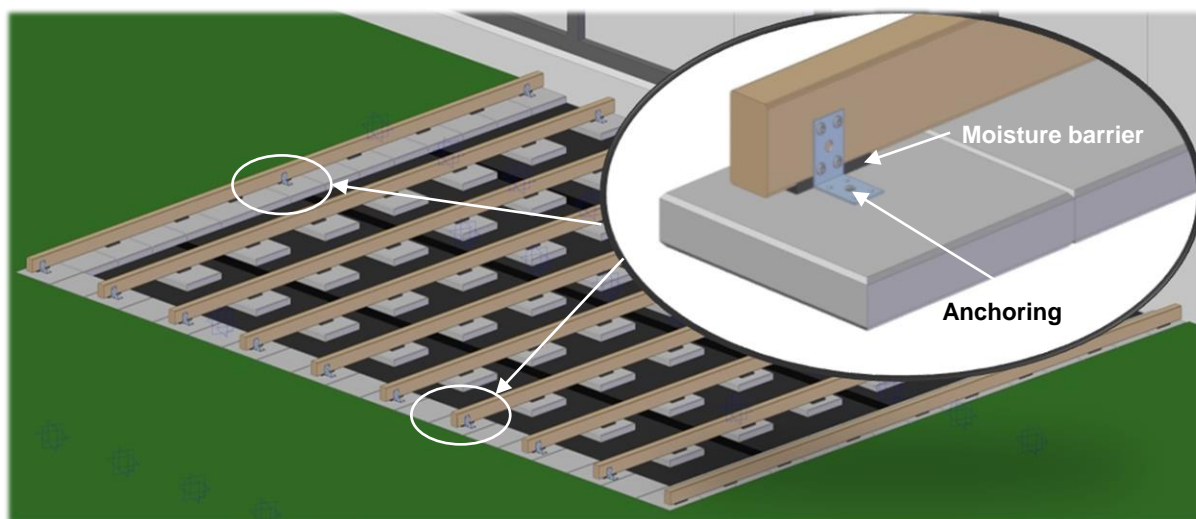

Figure 12: Example of beams at ground level. The beams are mounted on concrete slabs with EPDM spacers in between. This acts as a moisture barrier and raises the joists above the concrete slab, preventing moisture-wicking and allowing better drying of the wood. Angle brackets are used to anchor and stiffen the beams.

Decking above ground

The sizing of the beams and support structure must comply with the regulations. Cover the ground and soil mass under the decking to prevent the growth of vegetation.

Contact your local Kebony sales representative for questions and assistance with your project. See Kebony Use & Maintenance guide for care and longevity of your deck after installation.